

9055DR-18

Del Sol

18" x 18" Square

One piece drain grate.

1/2" maximum slot opening for A.D.A. compliance and pedestrian safety.

Cast from 100% recycled Iron, Aluminum, or Bronze for Pedestrian loads only.

Finish: Unfinished, or Black Dip, or Enamel Paint, or Polyurethane Paint, or Powder Coat. Zinc undercoat available.

Specify finish and color.

Use Frame Model: 9000FDR-18

Weight:
Iron= 32Lb / 15Kg
Aluminum=11Lb / 5Kg

DO NOT SCALE DRAWING

IRONSMITH
41-701 Corporate Way #3
Palm Desert, CA 92260
(800) 338-4766
(760) 776-5080 Fax

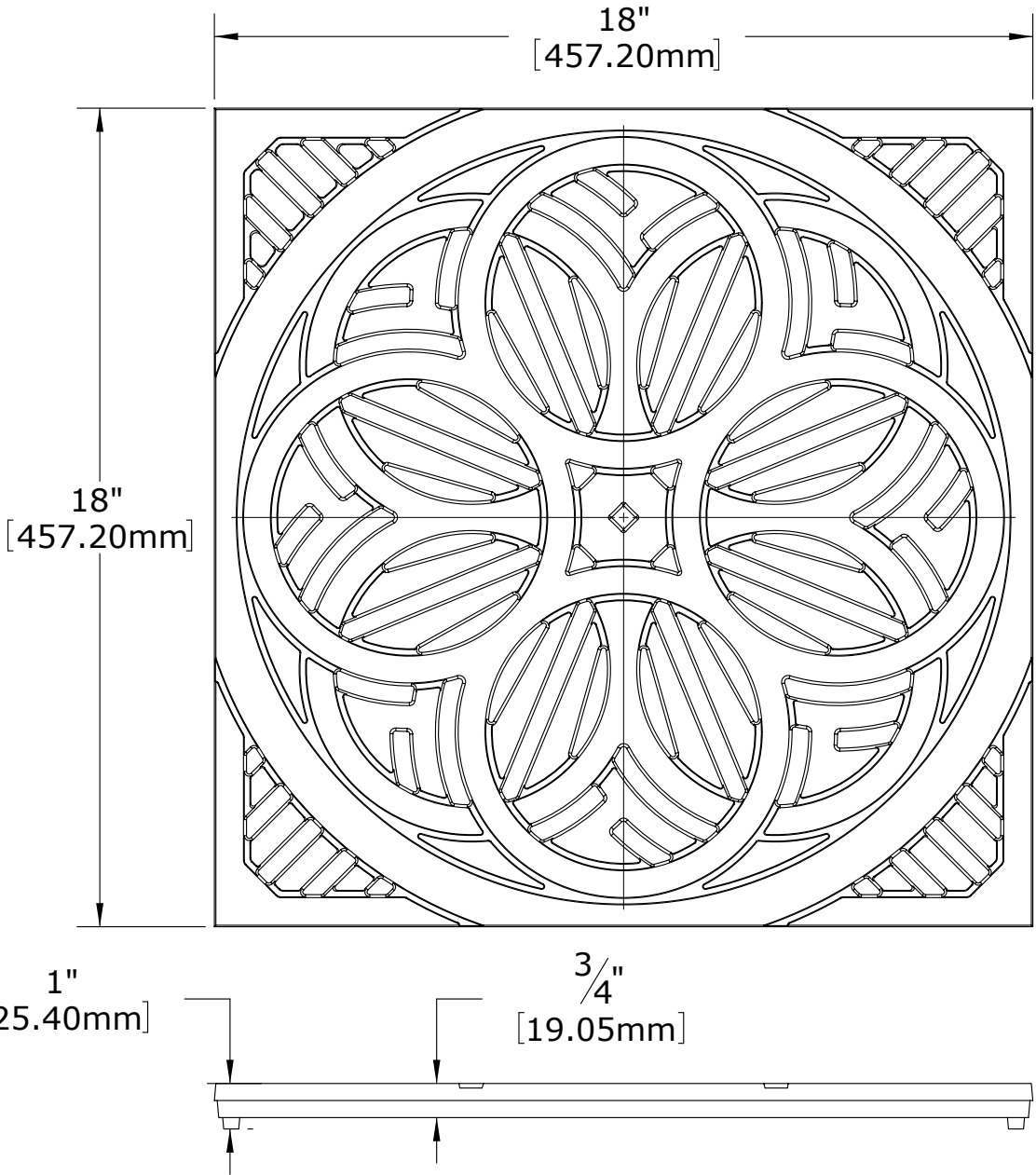

PROPRIETARY AND CONFIDENTIAL

This drawing embodies a confidential design of IRONSMITH, INC. Palm Desert, CA. All design, manufacturing, reproduction, use, sale, and other rights regarding the same are expressly reserved. This drawing is submitted under confidential relationship for a specific purpose and the recipient agrees by accepting this drawing not to supply or disclose any information regarding it to any unauthorized person or to incorporate any special feature peculiar to this design in other projects. The information in this drawing may be covered completely or in part by patents pending.